



## HDL-128 W (Lightline)

### CAMPANA DE TECHO



#### Datos Técnicos

<b>Categoría</b>	Campanas de Techo (Isla)
<b>Dimensión</b>	120 cm
<b>Tipo Extracción</b>	Interno (Recirculación)
<b>Acabado</b>	Aluminio + Cristal Templado

#### Prestaciones

<b>Flujo Máx.</b>	600 m <sup>3</sup> /h
<b>Máx. Nivel Sonoro</b>	58 dB(A)
<b>Total Absorción</b>	247 W
<b>Filtros</b>	Filtros de Acero Inox - Cassette - + Filtro Carbón Activo
<b>Control</b>	3S+1B App + Control Remoto
<b>Iluminación</b>	87W LED en Línea (RGB + TW)
<b>Tamaño del Conducto</b>	/

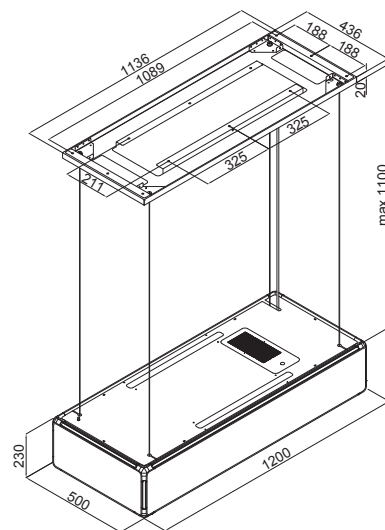

SILVERLINE  
www.silverline-home.com

**SILVERLINE**