



HDQ-64 I / 84 I

CAMPANA DE PARED



Datos Técnicos

Categoría	Campana de Pared
Dimensión	60 - 80cm
Tipo extracción	Interno (Salida libre/ Recirculación)
Acabado	Inox + Cristal Templado

Prestaciones

Flujo Máx.	644 m ³ /h (60cm) - 616 m ³ /h (80cm)
Máx. Nivel Sonoro	67 dB(A) (60cm) - 70 dB(A) (80cm)
Total Absorción	216W (60cm) - 213W (80cm)
Filtros	Filtros de acero Inox - cassette - + Opción Filtro Carbón Activos
Control	3S Touch Control
Iluminación	2x1,5W LED
Tamaño del conducto	150mm / 120mm

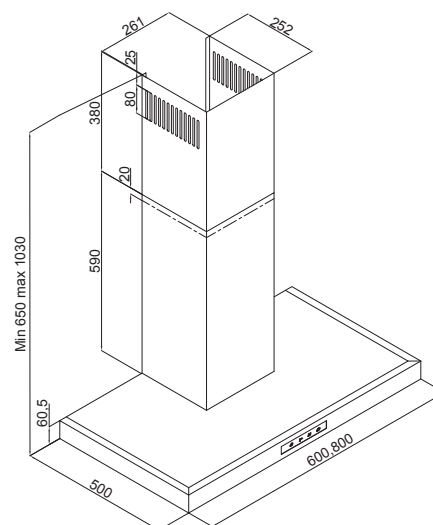

SILVERLINE
www.silverline-home.com

SILVERLINE